

INSTALLATION INSTRUCTIONS

CompactRIO™ R Series Expansion System

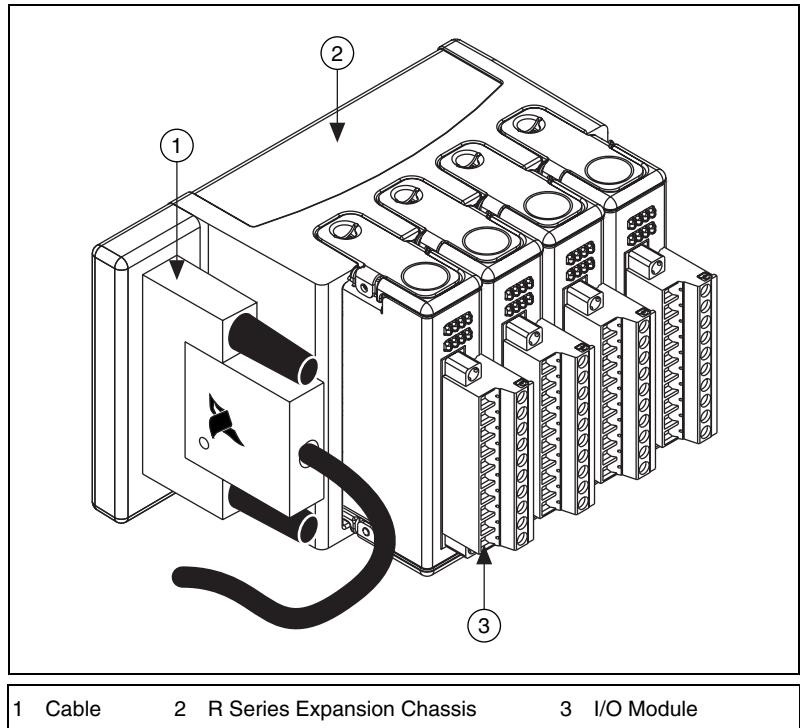

Figure 1. CompactRIO R Series Expansion System

These installation instructions describe how to install the National Instruments CompactRIO R Series expansion system. For information about wiring the I/O modules, and configuring and programming the CompactRIO system, refer to the *CompactRIO Bookshelf* at **Start» Program Files»National Instruments»CompactRIO»Search the CompactRIO Bookshelf.**

Safety Guidelines

Operate the cRIO-9151 only as described in these operating instructions.

Safety Guidelines for Hazardous Locations

The cRIO-9151 is suitable for use in Class I, Division 2, Groups A, B, C, and D hazardous locations; Class 1, Zone 2, AEx nC IIC T4 and Ex nC T4 hazardous locations; and nonhazardous locations only. Follow these guidelines if you are installing the cRIO-9151 in a potentially explosive environment. Not following these guidelines may result in serious injury or death.



Caution Do *not* disconnect I/O-side wires or connectors unless power has been switched off or the area is known to be nonhazardous.



Caution Do *not* remove modules unless power has been switched off or the area is known to be nonhazardous.



Caution Substitution of components may impair suitability for Class I, Division 2.



Caution For Zone 2 applications, install the CompactRIO system in an enclosure rated to at least IP 54 as defined by IEC 60529 and EN 60529.

Special Conditions for Safe Use in Europe

This equipment has been evaluated as EEx nC IIC T4 equipment under DEMKO Certificate No. 03 ATEX 0324020X. The chassis is marked  II 3G and is suitable for use in Zone 2 hazardous locations.

What You Need to Install the CompactRIO R Series Expansion Hardware

- CompactRIO R Series expansion chassis
- CompactRIO I/O modules
- Installed R Series device (For more information about installing an R Series device, refer to the user manual for the R Series device you are using.)
- SH68-C68-S cable
- DIN rail mount kit (for DIN rail mounting only)

- Two M4 or number 10 panhead screws (for panel mounting only)
- Number 2 Phillips screwdriver
- 1/8 in. flathead screwdriver

Mounting the CompactRIO R Series Expansion Chassis

You can mount the chassis in any orientation on a 35 mm DIN rail or on a panel. Use the DIN rail mounting method if you already have a DIN rail configuration or if you need to be able to quickly remove the CompactRIO chassis. Use the panel mount method for high shock and vibration applications.



Caution Your installation must meet the following requirements for space and cabling clearance:

- Allow 25.4 mm (1 in.) on the top and the bottom of the chassis for air circulation.
- Allow 50.8 mm (2 in.) in front of the modules for cabling clearance.

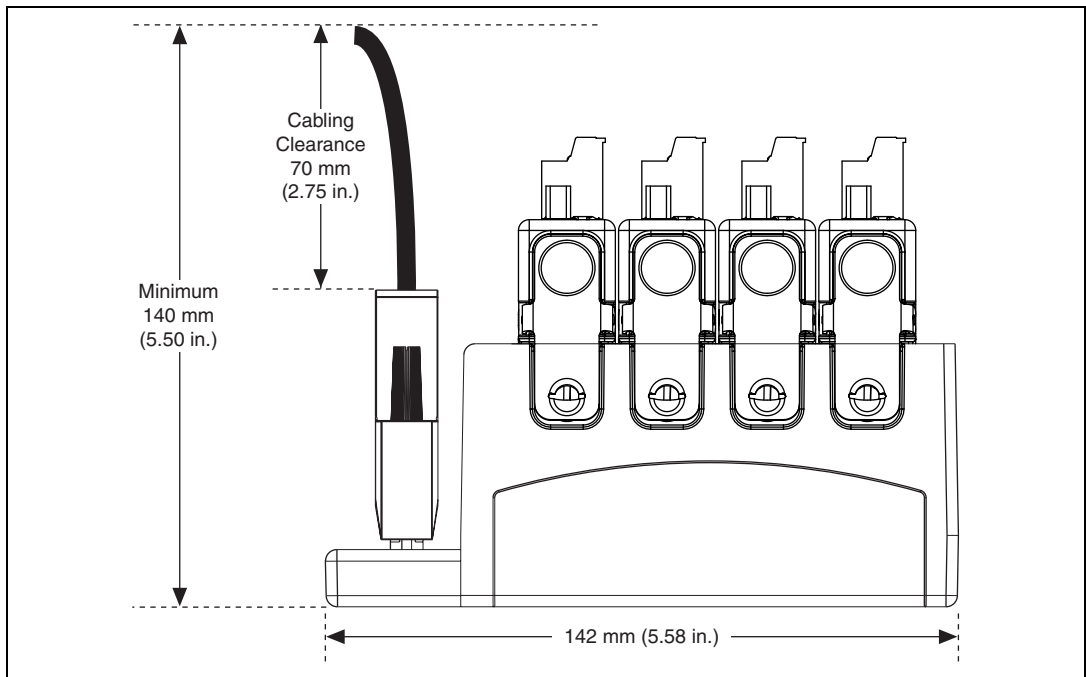

Figure 2. R Series Expansion Chassis with I/O Modules Installed, Bottom View with Dimensions

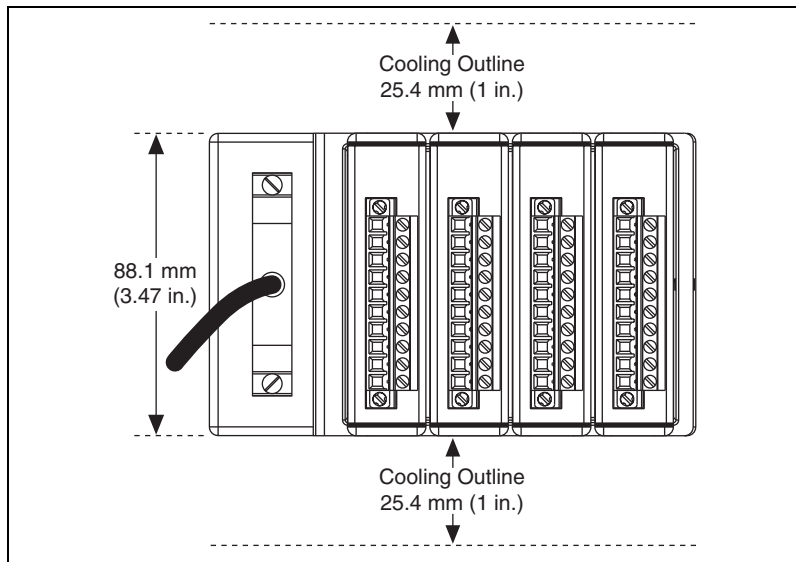

Figure 3. R Series Expansion Chassis with I/O Modules Installed, Side View with Dimensions

The following sections give instructions for the mounting methods. Before using any of these mounting methods, record the serial number from the back of the chassis. You will be unable to read the serial number after you have mounted the chassis.



Caution Before you mount the chassis, make sure the cable is *not* connected to the chassis.

Mounting the Chassis on a DIN Rail

You can order the cRIO-9912 DIN rail mount kit if you want to mount the CompactRIO chassis on a DIN rail. You need one clip for mounting the chassis on a standard 35 mm DIN rail. Complete the following steps to mount the chassis on a DIN rail.

1. Fasten the DIN rail clip to the chassis using a number 2 Phillips screwdriver and two M4x16 screws. The screws are included in the DIN rail mount kit.

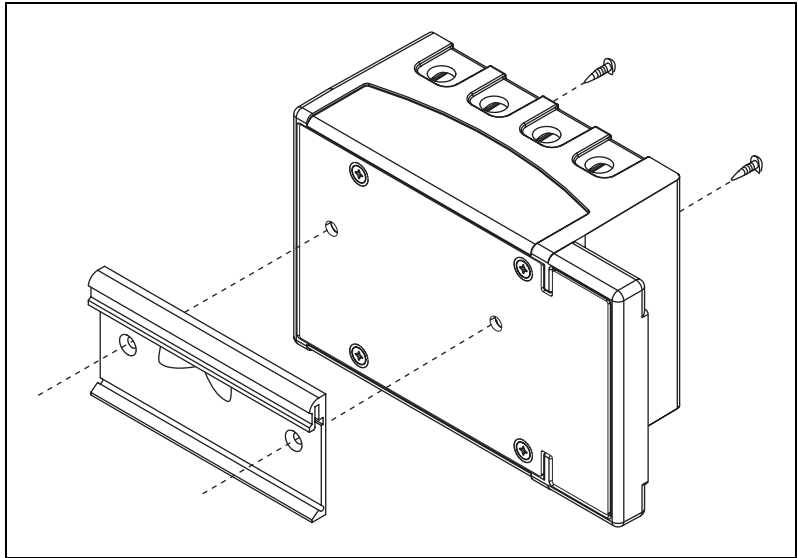

Figure 4. Fastening the DIN Rail Clip to the Chassis

2. Insert one edge of the DIN rail into the deeper opening of the DIN rail clip, as shown in Figure 5.

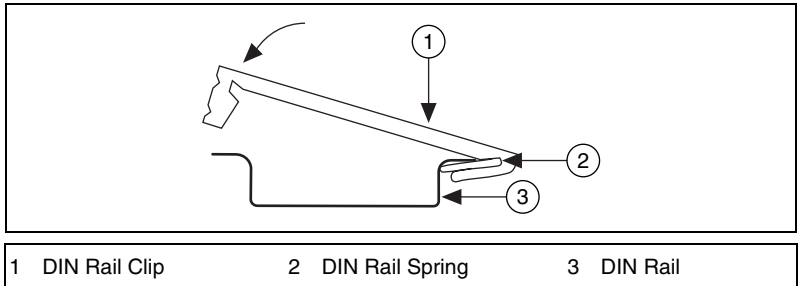

Figure 5. One Edge of the DIN Rail Inserted in a Clip

3. Press down firmly on the chassis to compress the spring until the clip locks in place on the DIN rail.



Caution Disconnect the cable from the chassis *before* removing the chassis from the DIN rail.

Mounting the Chassis on a Panel

You can mount the chassis on any material if the ambient temperature is 65 °C or less. If the ambient temperature is 66 to 70 °C, you must mount the chassis on a thermally conductive material. Measure the ambient temperature 50.8 mm (2 in.) from the end of the chassis. Complete the following steps to mount the chassis on a panel.

1. Align the chassis on the panel.
2. Bolt or screw the chassis to a panel using two M4 or number 10 panhead screws. National Instruments does not provide the screws with the chassis.

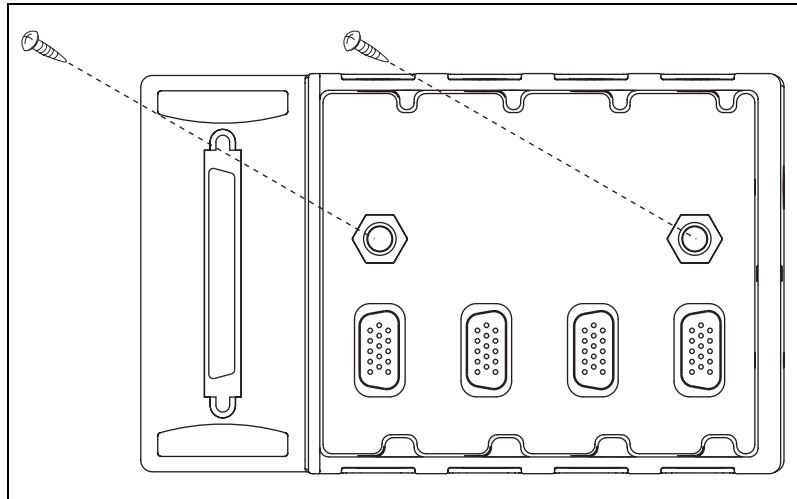

Figure 6. Mounting the Chassis on a Panel



Caution Disconnect the cable from the chassis *before* removing the chassis from the panel.

Installing CompactRIO I/O Modules in the Chassis

1. Make sure that no I/O-side power is connected to the I/O module. If the system is in a nonhazardous location, the chassis power can be on when you install I/O modules.
2. Align the I/O module with an I/O module slot in the chassis as shown in Figure 7. The module slots are labeled 1 to 4, left to right.

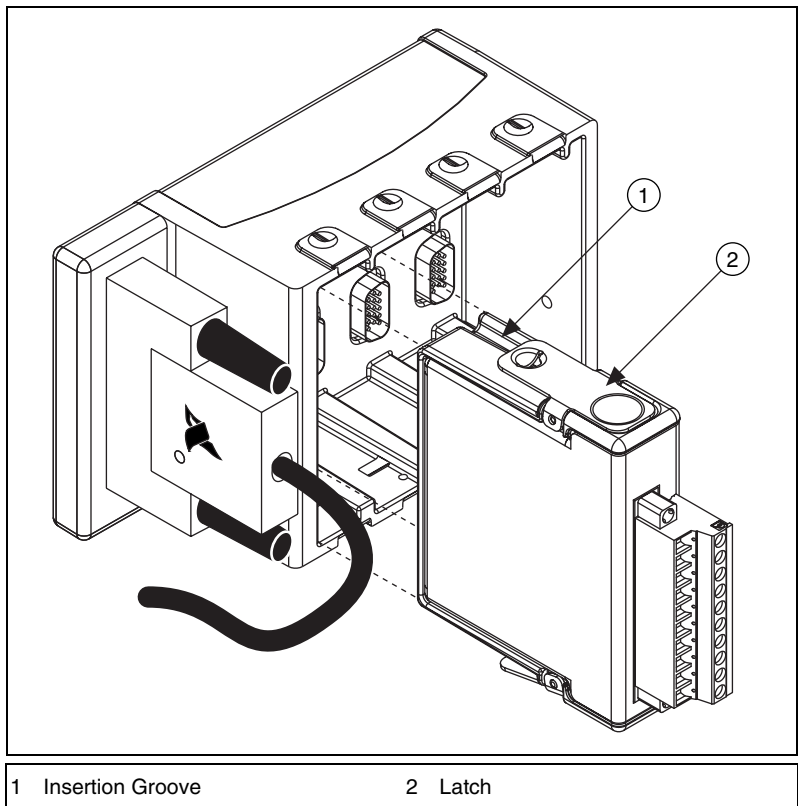

Figure 7. Installing an I/O Module in the Chassis

3. Squeeze the latches and insert the I/O module into the module slot.
4. Press firmly on the connector side of the I/O module until the latches lock the I/O module into place.
5. Repeat these steps to install additional I/O modules.

Removing I/O Modules from the Chassis

1. Make sure that no I/O-side power is connected to the I/O module.
2. Squeeze the latches on both sides of the module and pull the module out of the chassis.

Connecting I/O Modules to Field Devices

Refer to the operating instructions for each I/O module to help you connect field devices. You can find the operating instructions in the *CompactRIO Bookshelf* at **Start»Program Files»National Instruments»CompactRIO»Search the CompactRIO Bookshelf** or at ni.com/manuals.

Connecting the Chassis to Earth Ground

You must connect the green panhead screw at the end of the chassis to ground. If you are using shielded cables for the I/O module wiring, you can connect the shield to the panhead screw.

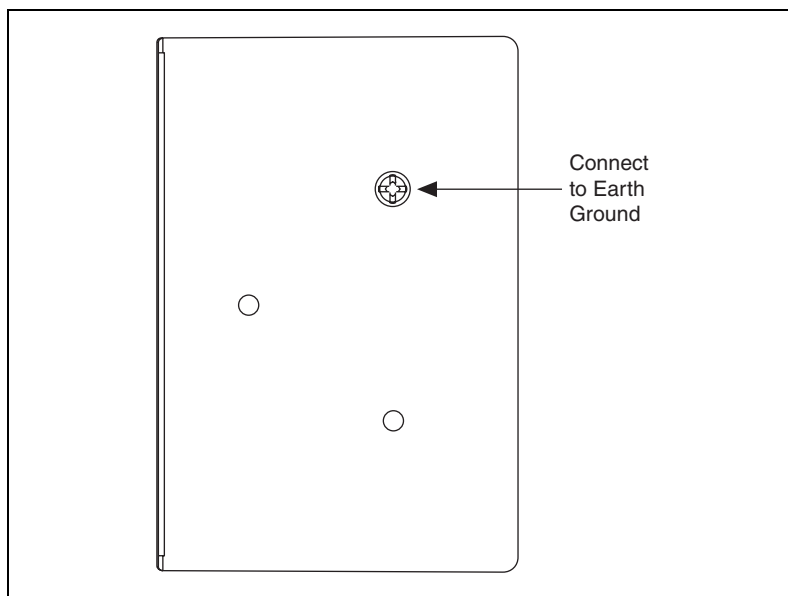

Figure 8. Connecting the Chassis to Earth Ground

Connecting the Chassis to the R Series Device

Using a SH68-C68-S cable, connect the R Series expansion chassis to the R Series device.

Where to Go from Here

You have completed installing the CompactRIO hardware. Now you need to configure the I/O modules and develop your program in LabVIEW. Refer to the *CompactRIO User Manual* for more information. You can find the *CompactRIO User Manual* at **Start»Program Files»CompactRIO»Search the CompactRIO Bookshelf** or at ni.com/manuals.

Specifications

The following specifications are typical for the range -40 to 70 °C unless otherwise noted. These specifications are for the cRIO-9151 expansion chassis only. For I/O module specifications, refer to the operating instructions for the I/O modules you are using.

Power Requirements

These power requirements are for a full-loaded chassis and exclude the power requirements of the I/O modules in the chassis. Make sure your CompactPCI chassis or PXI chassis meets the power requirements for the cRIO-9151 and CompactRIO I/O modules. For more information about the I/O module power requirements, refer to the operating instructions for the I/O module you are using.

Chassis power consumption

Active mode..... 0.5 W max

Sleep mode..... The cRIO-9151 does not support sleep mode.

Physical Characteristics

Chassis weight..... Approx. 527 g (18.6 oz)

Safety

Safety Standards

The cRIO-9151 is designed to meet the requirements of the following standards of safety for electrical equipment for measurement, control, and laboratory use:

- EN 61010-1, IEC 61010-1
- UL 3111-1, UL 61010B-1
- CAN/CSA C22.2 No. 1010.1



Note For UL and other safety certifications, refer to the product label or visit ni.com/hardref.nsf, search by model number or product line, and click the appropriate link in the Certification column.

Hazardous Locations

| | |
|----------------------|--|
| U.S. (UL) | Class I, Division 2, Groups A, B, C, D, T4; Class I, Zone 2, AEx nC IIC T4 |
| Canada (C-UL) | Class I, Division 2, Groups A, B, C, D, T4; Class I, Zone 2, AEx nC IIC T4 |
| Europe (DEMKO) | EEx NC IIC T4 |

Environmental

CompactRIO systems are intended for indoor use only. For outdoor use, mount the CompactRIO system in a suitably rated enclosure.

| | |
|------------------------------------|-----------------------------|
| Operating temperature | -40 to 70 °C |
| Storage temperature | -40 to 85 °C |
| Ingress protection | IP 40 |
| Operating humidity | 10 to 90% RH, noncondensing |
| Storage humidity | 5 to 95% RH, noncondensing |
| Maximum altitude | 2,000 m |
| Pollution Degree (IEC 60664) | 2 |

Shock and Vibration

To meet these specifications, you must panel mount the CompactRIO system and affix ferrules to the ends of the terminal lines.

| | |
|---|--|
| Operating vibration, random (IEC 60068-2-64)..... | 5 g _{rms} , 10 to 500 Hz |
| Operating shock (IEC 60068-2-27)..... | 30 g, 11 ms half sine, 50 g, 3 ms half sine, 18 shocks at 6 orientations |
| Operating vibration, sinusoidal (IEC 60068-2-6)..... | 5 g, 10 to 500 Hz |

Electromagnetic Compatibility

| | |
|-----------------|--|
| Emissions | EN 55011 Class A at 10 m FCC Part 15A above 1 GHz |
| Immunity | Nonindustrial levels per EN 61326-1:1997 + A2:2001, Table 1 |
| EMC/EMI..... | CE, C-Tick, and FCC Part 15 (Class A) Compliant |



Note For EMC compliance, you *must* operate this device with shielded cabling. The device must be connected to earth ground. For more information about connecting the device to earth ground, refer to the [Connecting the Chassis to Earth Ground](#) section.

CE Compliance

This product meets the essential requirements of applicable European directives, as amended for CE marking, as follows:

| | |
|--|------------|
| Low-Voltage Directive (safety) | 73/23/EEC |
| Electromagnetic Compatibility Directive (EMC) | 89/336/EEC |



Note Refer to the Declaration of Conformity (DoC) for this product for any additional regulatory compliance information. To obtain the DoC for this product, visit ni.com/hardref.nsf, search by model number or product line, and click the appropriate link in the Certification column.

National Instruments Contact Information

Go to ni.com/support for the most current manuals, examples, and troubleshooting information. For telephone support in the United States, create a service request at ni.com/ask and follow the calling instructions or dial 512 795 8248. For telephone support outside the United States, contact your local branch office:

Australia 1800 300 800, Austria 43 0 662 45 79 90 0,
Belgium 32 0 2 757 00 20, Brazil 55 11 3262 3599,
Canada (Calgary) 403 274 9391, Canada (Ottawa) 613 233 5949,
Canada (Québec) 450 510 3055, Canada (Toronto) 905 785 0085,
Canada (Vancouver) 514 685 7530, China 86 21 6555 7838,
Czech Republic 420 224 235 774, Denmark 45 45 76 26 00,
Finland 385 0 9 725 725 11, France 33 0 1 48 14 24 24,
Germany 49 0 89 741 31 30, Greece 30 2 10 42 96 427,
India 91 80 51190000, Israel 972 0 3 6393737, Italy 39 02 413091,
Japan 81 3 5472 2970, Korea 82 02 3451 3400, Malaysia 603 9131 0918,
Mexico 001 800 010 0793, Netherlands 31 0 348 433 466,
New Zealand 0800 553 322, Norway 47 0 66 90 76 60,
Poland 48 22 3390150, Portugal 351 210 311 210,
Russia 7 095 783 68 51, Singapore 65 6226 5886,
Slovenia 386 3 425 4200, South Africa 27 0 11 805 8197,
Spain 34 91 640 0085, Sweden 46 0 8 587 895 00,
Switzerland 41 56 200 51 51, Taiwan 886 2 2528 7227,
Thailand 662 992 7519, United Kingdom 44 0 1635 523545

CompactRIO™, LabVIEW™, National Instruments™, NI™, and ni.com™ are trademarks of National Instruments Corporation. Product and company names mentioned herein are trademarks or trade names of their respective companies. For patents covering National Instruments products, refer to the appropriate location: **Help»Patents** in your software, the `patents.txt` file on your CD, or ni.com/patents.

© 2003 National Instruments Corp. All rights reserved.



323560A-01

Oct03